

Pressure/Vacuum Diaphragm Valve

Deflagration-proof and Endurance Burning-proof

PROTEGO® UB/SF

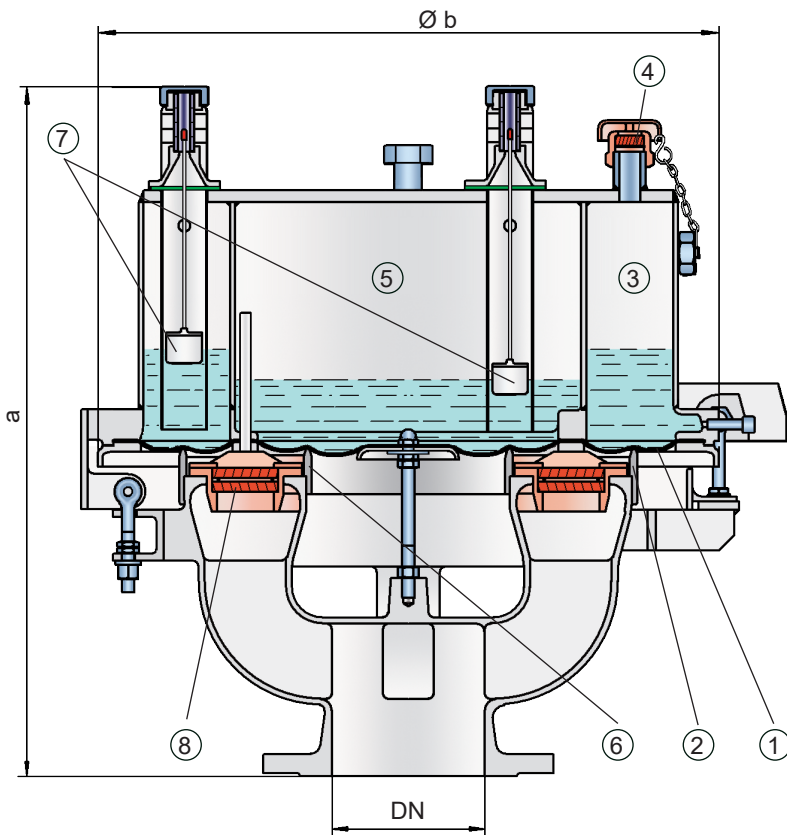

The set pressure is adjusted with a freeze resistant water-glycol mixture which ensures safe operation under extreme cold weather conditions. The PROTEGO® UB/SF valve is available for substances from explosion group IIB3. When the pressure in the tank reaches the set pressure, the diaphragm (1) on the outer valve seat ring (2) is lifted and vapors are released into environment. The set pressure is adjusted by weight of the liquid load (water-glycol mixture) in the outer ring chamber (3). The overpressure chamber is equipped with an opening (4) to keep the pressure in balance. The opening is equipped with a FLAMEFILTER® to prevent flame transmission into the overpressure chamber. If a vacuum builds up in the tank, it is transferred to the vacuum chamber (5) (inner chamber) through pressure balancing tubes. If the set vacuum is reached, the atmospheric pressure lifts the diaphragm of the inner valve seat ring (6), resulting in ventilation of the tank. Both the overpressure and underpressure are adjusted via the filling level of the load liquid in the various chambers and can be checked by floating level indicators (7).

The tank pressure is maintained up to the set pressure with a tightness that is above the normal standards due to our highly developed manufacturing technology. This is achieved by the liquid loaded

diaphragm pressing tightly around the special designed valve seat surface area even when the operating pressure increases, which reduces surface pressure and unnecessary leakage. After the overpressure is released, the valve re-seats and provides a tight seal.

If the set pressure is exceeded, explosive gas/product vapor/air mixtures are released into the atmosphere. The speed at which these mixtures exit the annular gap between the diaphragm and the outer valve seat ring is considerably greater than the flame speed. If this mixture ignites, flashback into the tank is prevented. If the mixture flow continues, the dynamic flame arresting feature prevents a flashback, even in the case of endurance burning. Even at relatively low flow rates, e.g., during thermal out-breathing, the gap formed by the volumetric flow is so narrow, that flames in the gap are extinguished and a flashback is prevented. At very low pressure settings, the explosion pressures resulting from an atmospheric deflagration may be strong enough to lift the diaphragm off the valve seat rings. The ignition into the tank can be prevented by installing the PROTEGO® flame arrester unit (8). This PROTEGO® flame arrester unit provides additional protection against atmospheric deflagration when the valve is open for maintenance and inspection.

The valve can be used at an operating temperature of up to +60°C /140°F and meets the requirements of European tank design standard EN 14015 (Appendix L) and ISO 28300 (API 2000)

EU conformity according to the currently valid ATEX directive. Approvals according to other national/international regulations on request.

Settings:

| | | | |
|------------------|--------|----------------|-----------------------|
| pressure: | DN 80 | +3.5 mbar | up to +50 mbar |
| | | +1.4 inch W.C. | up to +20 inch W.C. |
| | DN 100 | +3.5 mbar | up to +45 mbar |
| | | +1.4 inch W.C. | up to +18 inch W.C. |
| | DN 150 | +3.5 mbar | up to +46 mbar |
| | | +1.4 inch W.C. | up to +18.4 inch W.C. |

Higher pressure settings up to +140 mbar (56.2 inch W.C.) in special design with additional liquid reservoir as well as lower pressure settings upon request.

| | | |
|----------------|----------------|---------------------|
| vacuum: | -3.5 mbar | up to -35 mbar |
| | -1.4 inch W.C. | up to -14 inch W.C. |

Higher vacuum settings upon request.

Function and Description

The PROTEGO® UB/SF diaphragm valve is the only deflagration-proof and endurance burning-proof valve of its kind in the world. It is a highly developed combined pressure and vacuum valve with dynamic and static flame arrester. It is primarily used as a safety device for flame transmission-proof in-breathing and out-breathing on tanks, containers, and process equipment. The valve provides reliable protection against overpressure and vacuum, prevents the in-breathing of air and product losses almost up to the set pressure, and protects against atmospheric deflagration and endurance burning if stabilized burning occurs. The PROTEGO® UB/SF diaphragm valve has proven itself over many years under a wide variety of operating conditions in the mineral oil and chemical industries. Worldwide, it is the only vent which works reliably with problem products such as Styrene or Acrylates.



UB/SF-IIB3
(Flyer pdf)



Frost-Proof P/V Diaphragm
Valve (Video)

Special Features and Advantages

- excellent tightness, resulting in lowest possible product losses and environmental pollution
- set pressure close to opening pressure for optimum pressure maintenance in the system
- high flow capacity
- can be used as a protective system in areas with potentially explosive atmospheres in accordance with ATEX
- protection against atmospheric deflagrations and endurance burning for products up to explosion group IIB3 (NEC group C MESH ≥ 0.65 mm)
- minimum pressure loss of the PROTEGO® flame arrester unit
- flame arrester venting and ventilation of the pressurized chamber
- optimal frost protection
- automatic condensate drain
- monitoring of the load liquid by level indicator
- easy operation monitoring and maintenance by simply opening the hinged valve cap
- modular design enables replacement of individual FLAMEFILTER® discs and diaphragm
- particularly suitable for problematic products such as styrene, acrylates, etc.
- digital level monitoring available to optimize maintenance intervals
- digital level sensors can be retrofitted to installed valves

Design Types and Specifications

The valve can be combined with almost any combination of vacuum and pressure settings. The diaphragm is pressurized by liquid. Higher pressures are available upon request in a special version with an additional attachment. When there is a substantial difference between the pressure and vacuum, special designs with weight-loaded vacuum discs are used.

There are two different designs:

Pressure/vacuum diaphragm valve, basic design **UB/SF - □**

Pressure/vacuum diaphragm valve with heating coil **UB/SF - □^H**
(max. heating fluid temperature +85°C / 185°F)

In addition to the standard design, a series of specially developed designs (e.g., for acrylate or styrene storage tanks, etc.) can be provided upon request.

Remark

$$\text{set pressure} = \frac{\text{opening pressure resp. tank design pressure}}{1,4}$$

Set pressure = the valve starts to open

Opening pressure = set pressure plus overpressure

Overpressure = pressure increase over the set pressure

Table 1: Dimensions

Dimensions in mm / inches

To select the nominal size (DN), please use the flow capacity charts on the following page.

| DN | pressure | 80 / 3" | pressure | 100 / 4" | pressure | 150 / 6" |
|----|----------------------------------|-------------|----------------------------------|-------------|--------------------------------|-------------|
| a | up to +28 mbar / +11.2 inch W.C. | 615 / 24.21 | up to +28 mbar / +11.2 inch W.C. | 645 / 25.39 | up to +25 mbar / +10 inch W.C. | 680 / 26.77 |
| a | > +28 mbar / +11.2 inch W.C. | 765 / 30.12 | > +28 mbar / +11.2 inch W.C. | 795 / 31.30 | > +25 mbar / +10 inch W.C. | 830 / 32.68 |
| b | | 410 / 16.14 | | 485 / 19.09 | | 590 / 23.23 |

Pressure settings > +50 mbar / +20 inch W.C. (DN 80/3"), > +45 mbar / +18 inch W.C. (DN 100/4"), > +46 mbar / +18.4 inch W.C. (DN150/6") with additional liquid reservoir - dimensions upon request.

Dimensions for pressure/vacuum diaphragm valves with heating coil upon request.

Table 2: Selection of explosion group

| MESH | Expl. Gr. (IEC/CEN) | Gas Group (NEC) | Special approvals upon request. |
|----------------|---------------------|-----------------|---------------------------------|
| $\geq 0,65$ mm | IIB3 | C | |



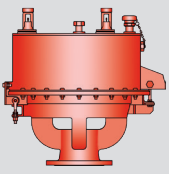

Pressure/Vacuum Diaphragm Valve

Deflagration-proof and Endurance Burning-proof

PROTEGO® UB/SF

Table 3: Material selection for housing

| | | |
|----------------------------|-----------------|-----------------|
| Design | C | D |
| Housing | Steel | Stainless Steel |
| Valve top | Stainless Steel | Stainless Steel |
| Heating coil (UB/SF-H-...) | Stainless Steel | Stainless Steel |
| Valve seats | Stainless Steel | Stainless Steel |
| Gasket | FPM | PTFE |
| Diaphragm | A, B | A, B |
| Flame arrester unit | C | C |

The housings are also available with an ECTFE coating.
Special materials upon request.



Coated Devices
(Flyer pdf)

Table 4: Material selection for diaphragm

| | | |
|-----------|-----|-----|
| Design | A | B |
| Diaphragm | FPM | FEP |

Special materials upon request.

Table 5: Material combinations of flame arrester unit

| | |
|---------------------|-----------------|
| Design | C |
| FLAMEFILTER® casing | Stainless Steel |
| FLAMEFILTER® | Stainless Steel |
| Spacer | Stainless Steel |

Special materials upon request.

Table 6: Flange connection type

| |
|------------------------|
| EN 1092-1; Form B1 |
| ASME B16.5 CL 150 R.F. |

Other types upon request.

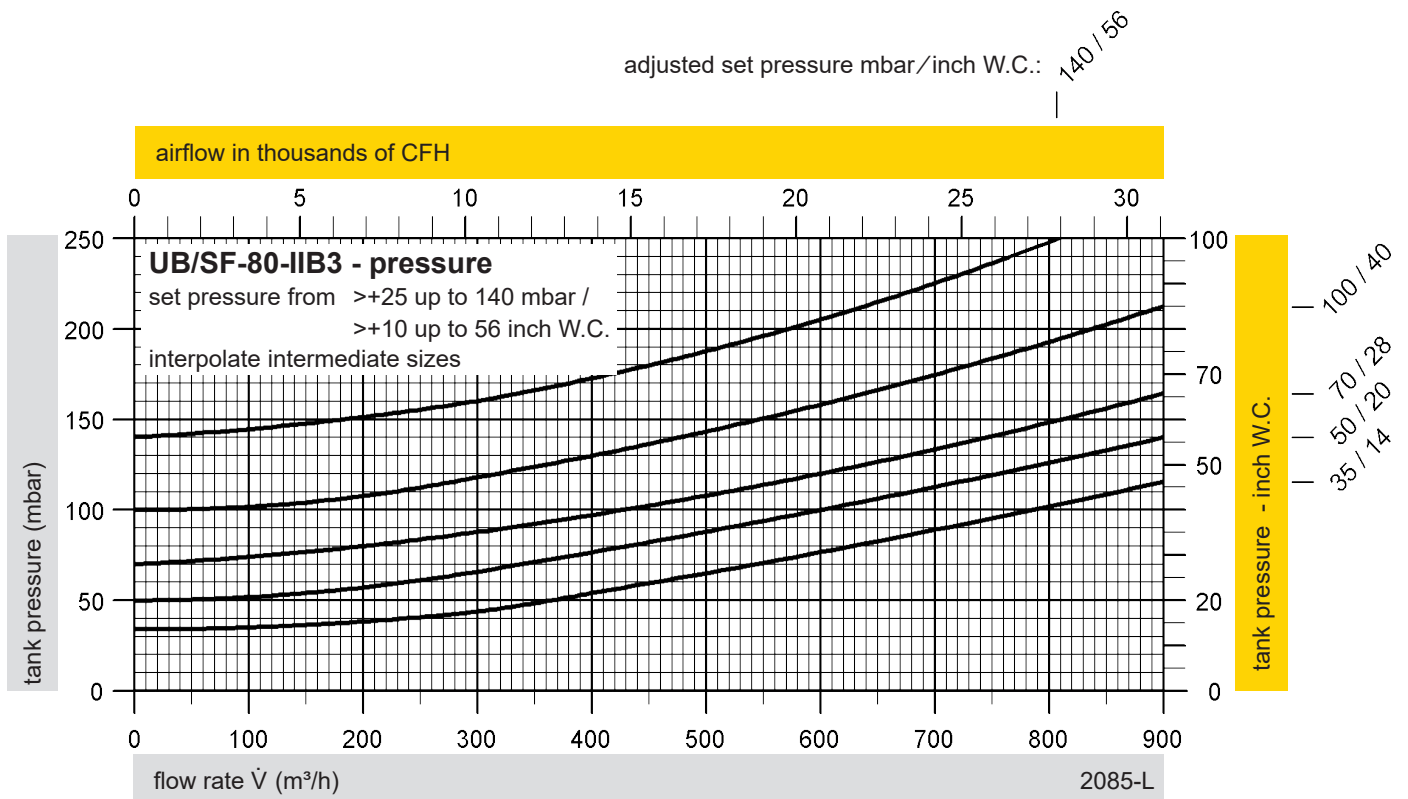
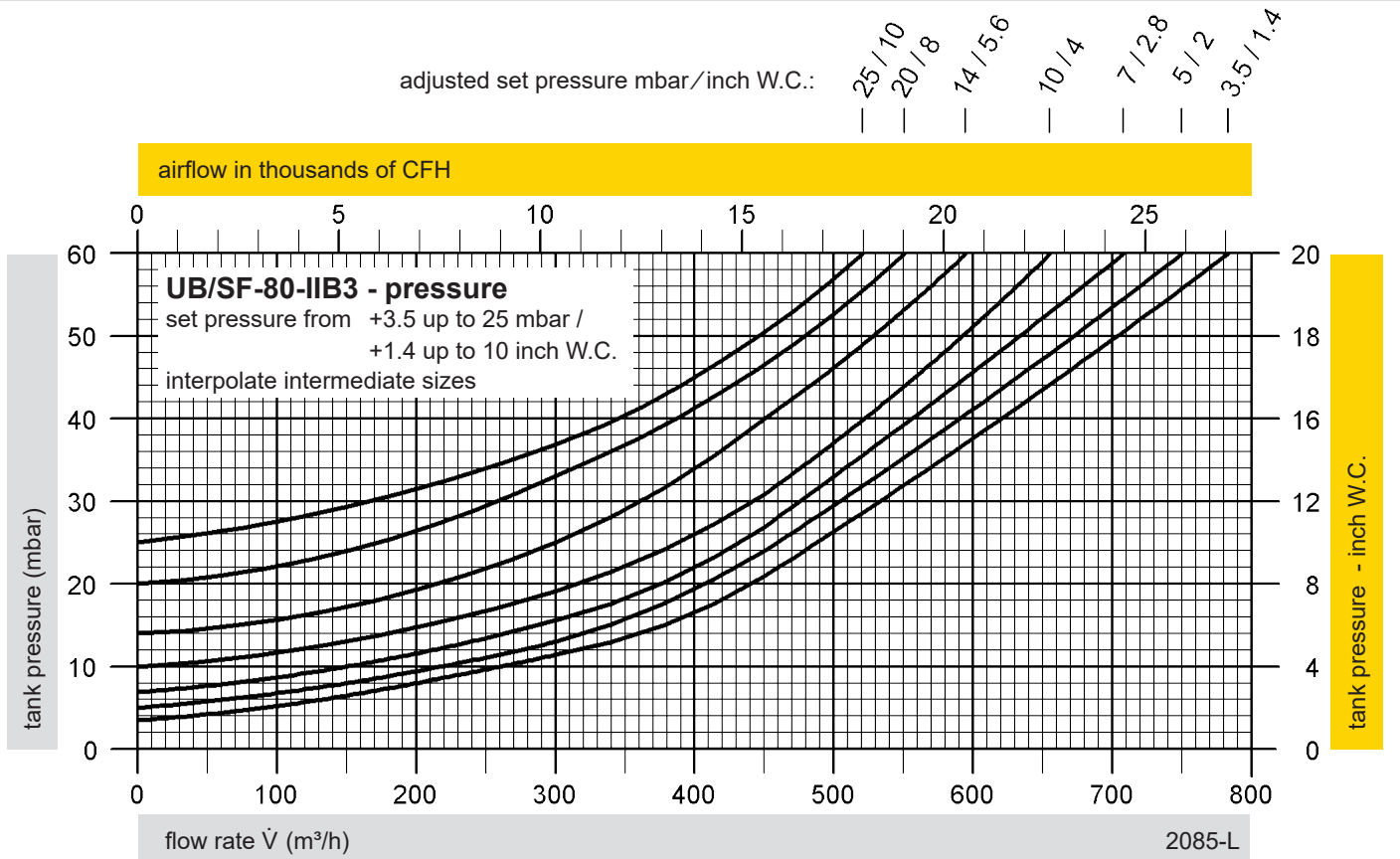

The flow capacity charts have been determined with a calibrated and TÜV certified flow capacity test rig.
 Volume flow \dot{V} in (m³/h) and CFH refer to the standard reference conditions of air in ISO 6358 (20°C, 1bar).
 For conversion to other densities and temperatures, refer to Sec. 1: "Technical Fundamentals."



for safety and environment

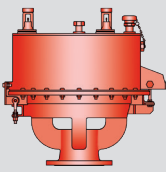

Pressure/Vacuum Diaphragm Valve

Flow Capacity Charts - Pressure

PROTEGO® UB/SF-100

adjusted set pressure mbar/inch W.C.: 25 / 10

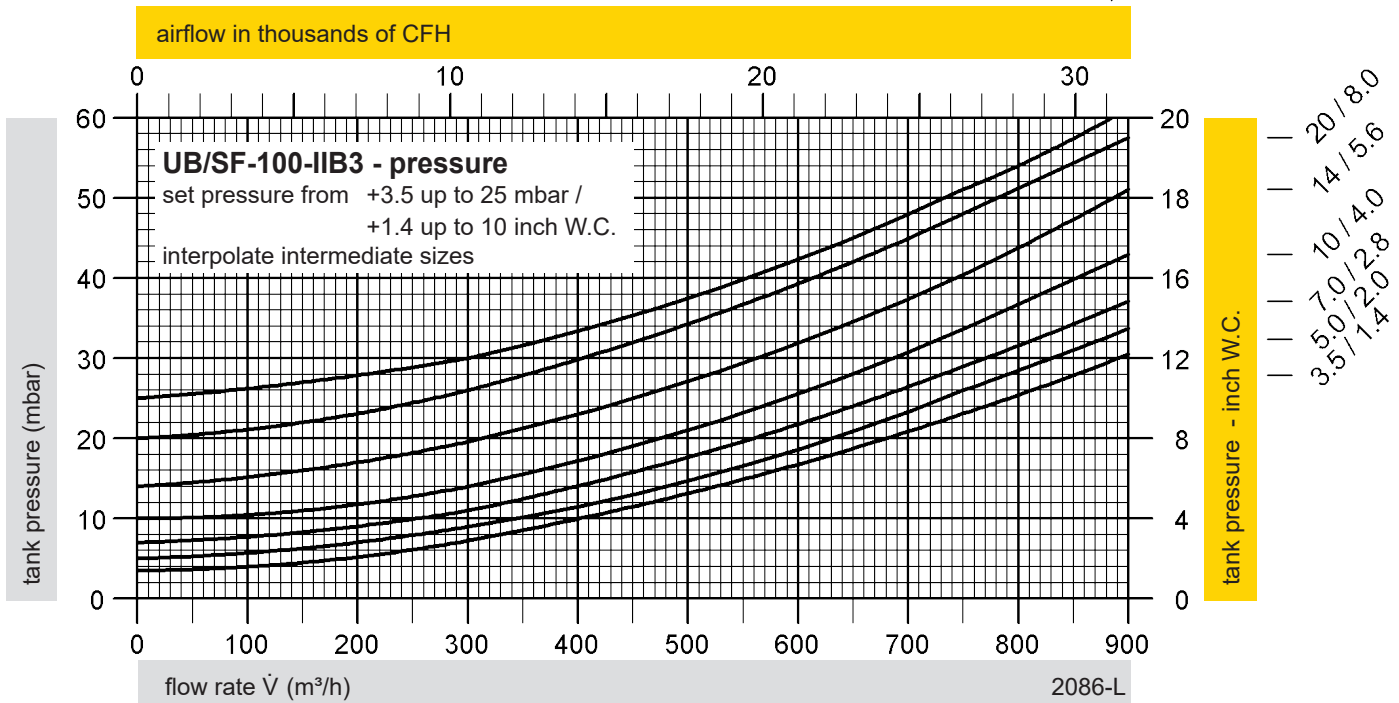

adjusted set pressure mbar/inch W.C.: 140 / 56

100 / 40

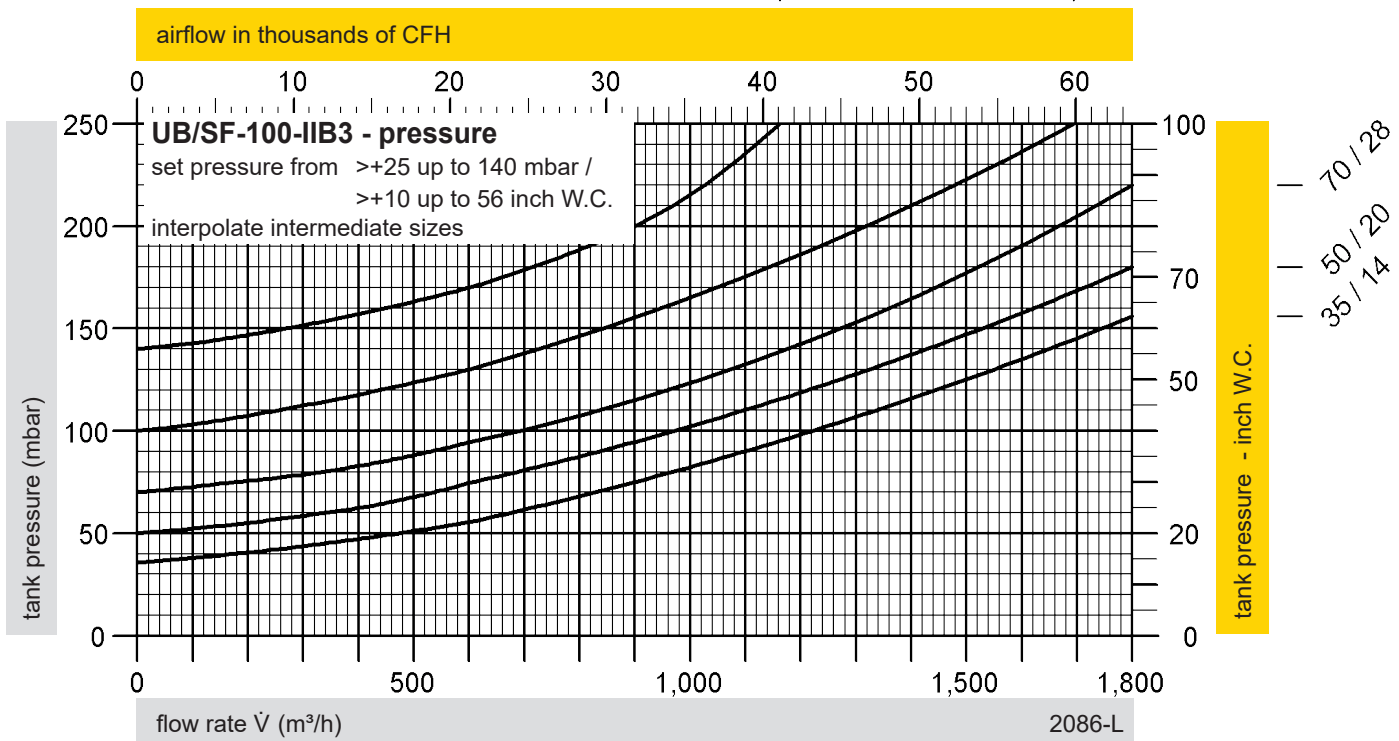

The flow capacity charts have been determined with a calibrated and TÜV certified flow capacity test rig. Volume flow \dot{V} in (m³/h) and CFH refer to the standard reference conditions of air in ISO 6358 (20°C, 1bar). For conversion to other densities and temperatures, refer to Sec. 1: "Technical Fundamentals."

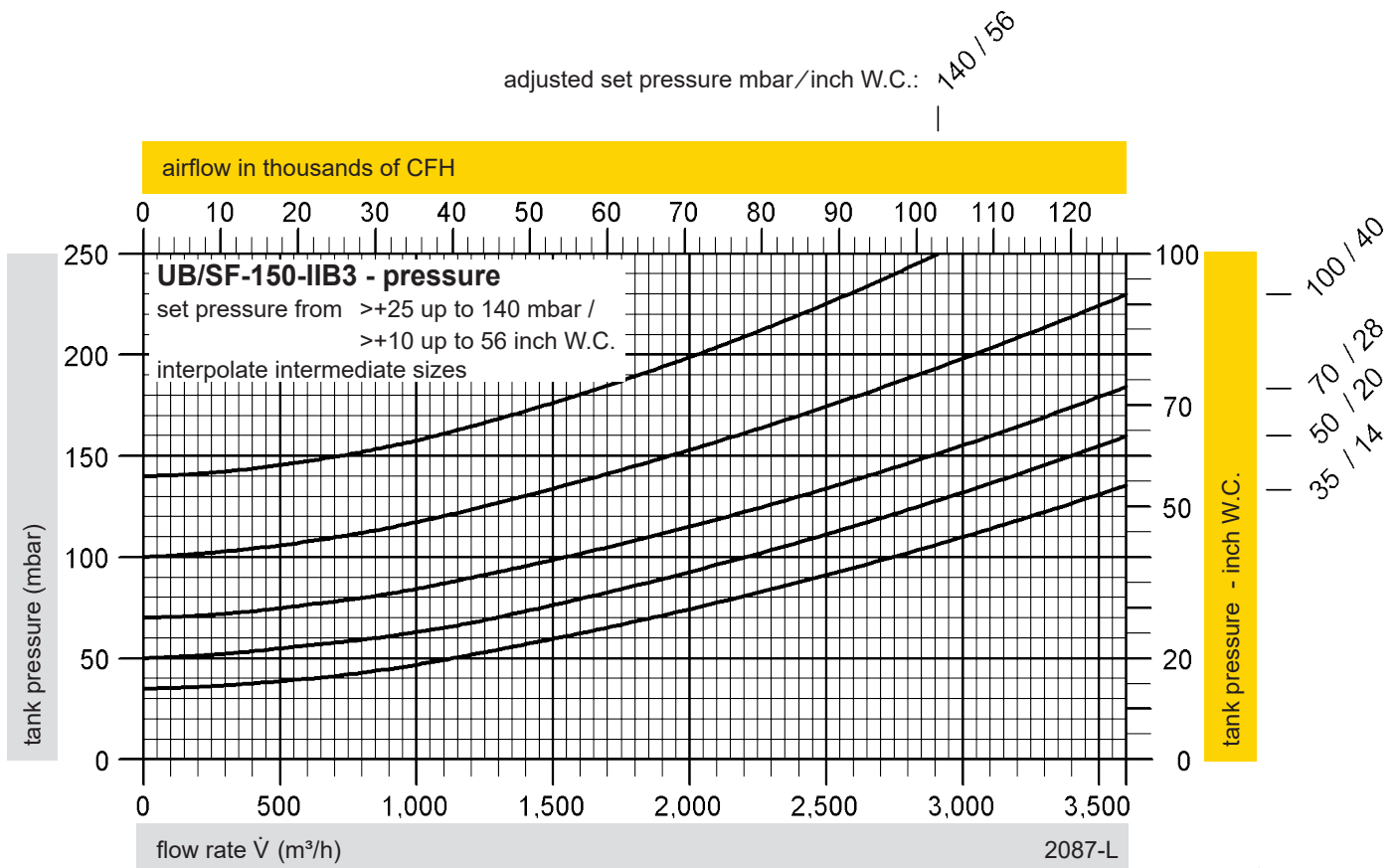
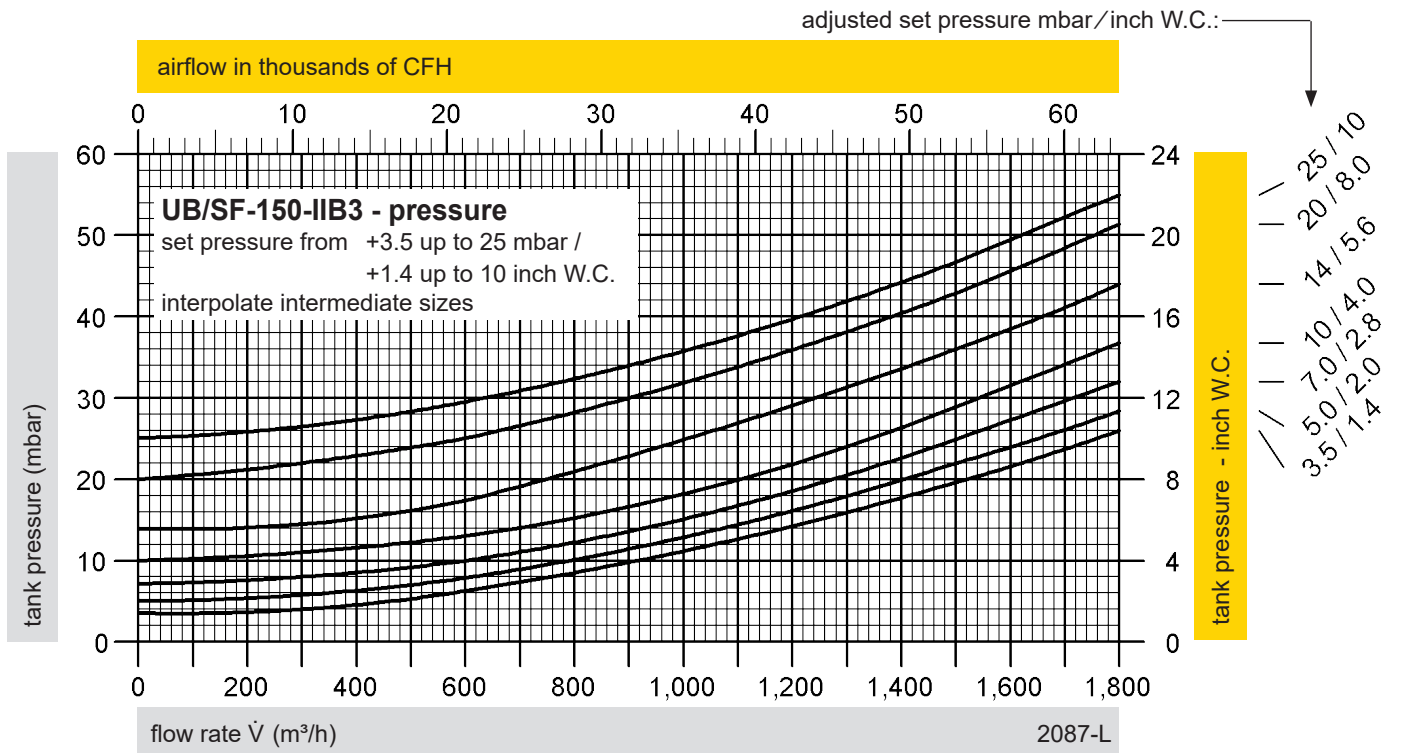

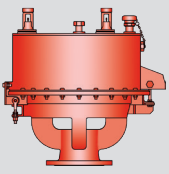

Pressure/Vacuum Diaphragm Valve

Flow Capacity Charts - Vacuum

PROTEGO® UB/SF-80 and 100

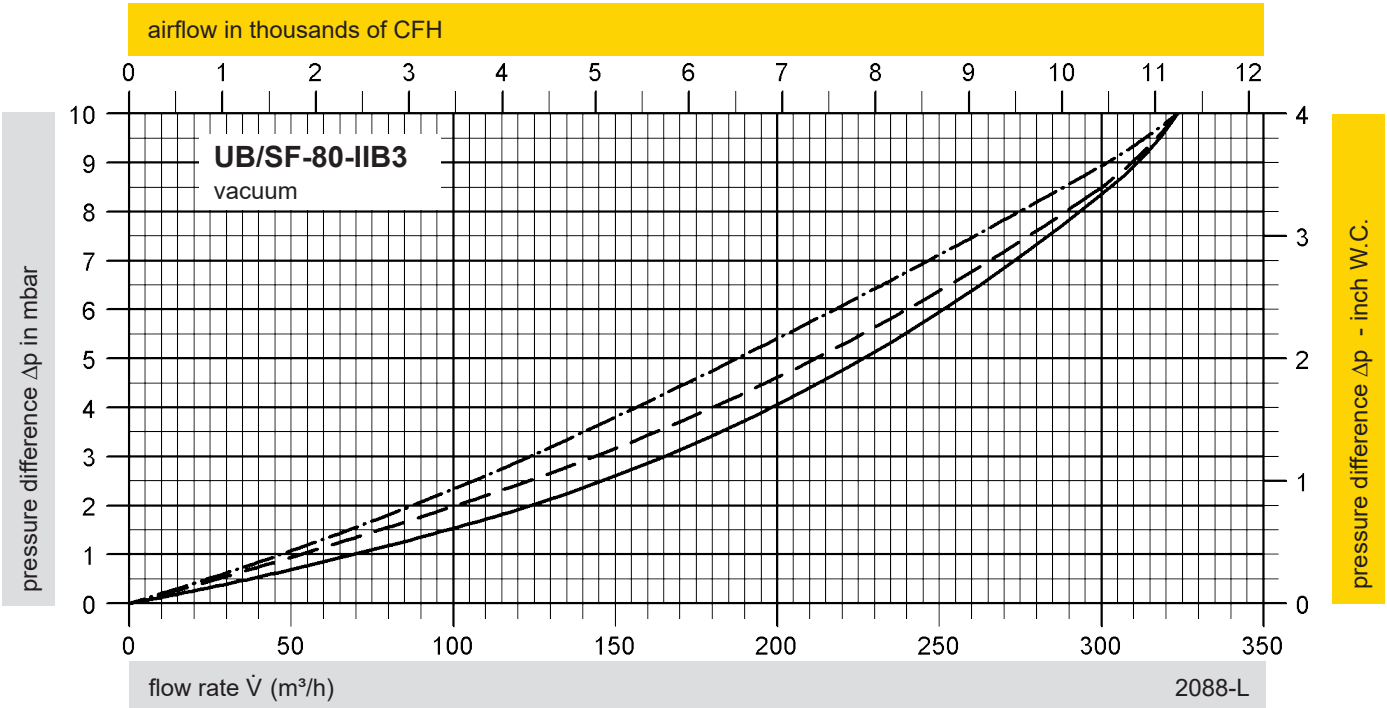

pressure difference = max. allowable tank design vacuum - valve set vacuum

adjusted set vacuum:

- ≤ -5 mbar / ≤ -2 inch W.C.
- - - > -5 mbar up to ≤ -7 mbar / > -2 inch W.C. up to ≤ -2.8 inch W.C.
- · - · > -7 mbar up to ≤ -35 mbar / > -2.8 inch W.C. up to ≤ -14 inch W.C.

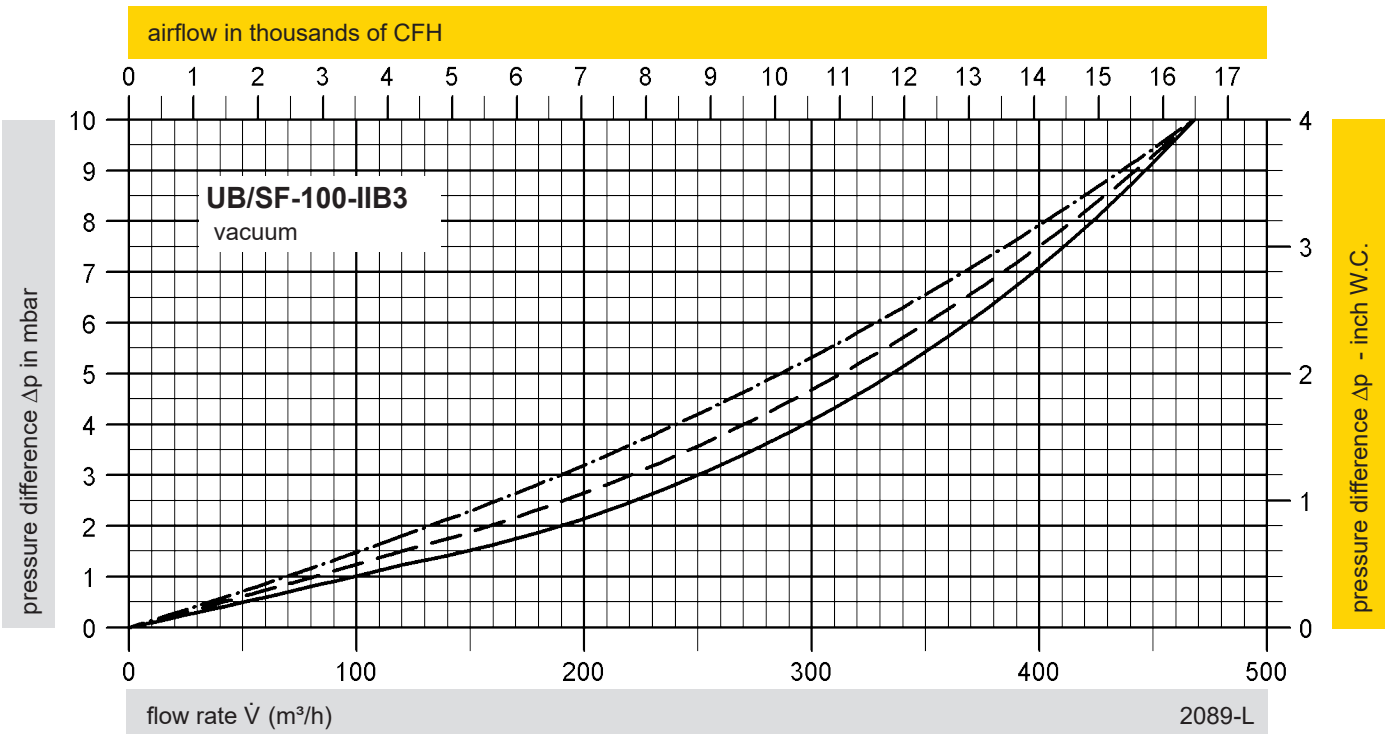

The flow capacity charts have been determined with a calibrated and TÜV certified flow capacity test rig.

Volume flow \dot{V} in (m³/h) and CFH refer to the standard reference conditions of air in ISO 6358 (20°C, 1bar).

For conversion to other densities and temperatures, refer to Sec. 1: "Technical Fundamentals."

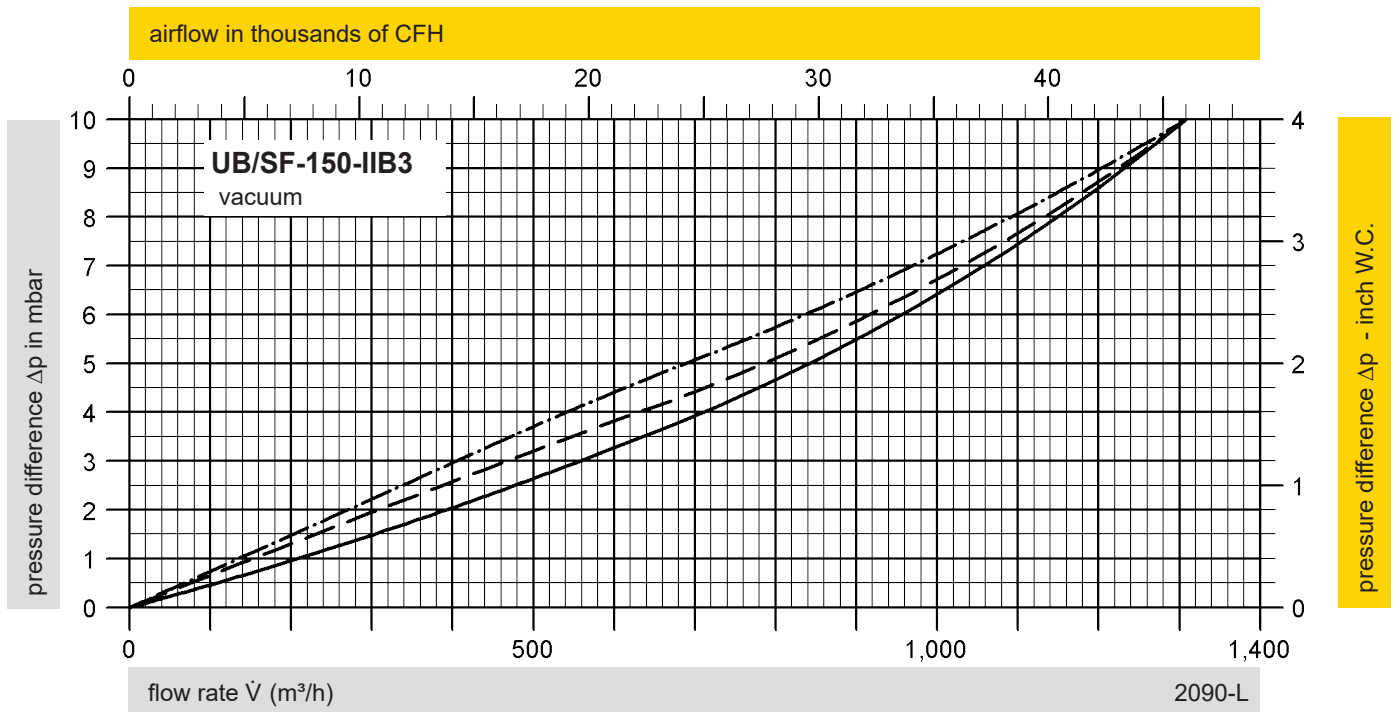

pressure difference = max. allowable tank design vacuum - valve set vacuum

adjusted set vacuum:

- ≤ -5 mbar / ≤ -2 inch W.C.
- - - - - > -5 mbar up to ≤ -7 mbar / > -2 inch W.C. up to ≤ -2.8 inch W.C.
- · - · - · > -7 mbar up to ≤ -35 mbar / > -2.8 inch W.C. up to ≤ -14 inch W.C.

