

Pressure/Vacuum Relief Valve

Pilot-operated diaphragm valve

PROTEGO® VN-A-PCPF

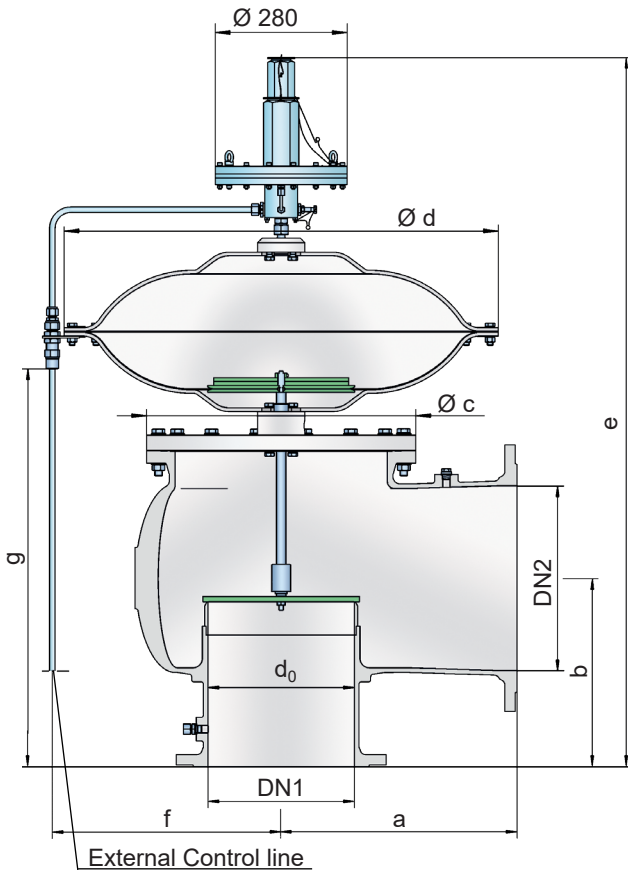

Settings:

Pressure*: +20 mbar up to +1034 mbar
 +8 inch W.C. up to +415.1 inch W.C.

Vacuum: -2.2 mbar up to -7 mbar
 -0.88 inch W.C. up to -2.8 inch W.C.

* Varies depending on the type and DN
 Other settings upon request.

Function and Description

The PROTEGO® Type VN-A-PCPF pilot-controlled diaphragm valve is a newly developed valve for pressure and vacuum relief. It is primarily used as a safety device for out-breathing in tanks, containers, and process equipment. It provides protection against vacuum and overpressure and prevents the intake of air and unallowable product vapor loss up to the set pressure.

The valve can also be used as an in-breathing valve where the main valve is directly controlled when it is exposed to a vacuum, i.e., it functions as a weight-loaded diaphragm valve.

The main valve is controlled by a pilot valve which is controlled by the tank pressure. The set pressure is adjusted by increasing or decreasing the tension on the spring on the pilot valve.

As the pressure increases, the closing force on the main valve increases, i.e., the valve becomes tighter with increasing tank pressure until the set pressure is reached. Once the valve has started to lift, it opens fully within a 10% of the pressure increase or opening pressure difference, and the nominal volume flow is released through a fully open valve. If and when this level is exceeded, the pressure increase will follow the performance

curve ($\Delta p/\dot{V}$ curve). From set pressure to full capacity (fully open valve), the pressure increase is 100% in case of vacuum venting/in-breathing function.

The tank pressure is maintained up to the set pressure with a tightness that is above the normal standards due to our highly developed manufacturing technology. This feature is ensured by valve seats made of high quality stainless steel with precisely lapped valve discs. After the overpressure is released or the vacuum is balanced, the valve re-seats and provides a tight seal.

Special Features and Advantages

- controlled by corrosion-resistant control valve (pilot valve)
- flow modulated pilot valve
- max. 10% pressure increase till full lift
- extreme tightness, resulting in lowest possible product losses and reduced emissions
- set pressure close to opening pressure for optimum pressure maintenance in the system
- highest flow capacity
- suitable for use in explosive atmosphere
- designed for use at cryogenic temperature

Design Types and Specifications (basic design)

Pressure/vacuum relief valve with spring pilot **VN-A-PCPF** valve

Pressure relief valve; vacuum function prevented by check valve **VN-A-PCPF-NV**

Pressure relief valve; vacuum function prevented by a diaphragm decoupled from the valve pallet **VN-A-PCPF-ANV**

Pressure/vacuum relief valve with Field-Test-Connection **VN-A-PCPF-FT**

Pressure relief valve; vacuum function prevented by check valve and with Field-Test-Connection **VN-A-PCPF-NV-FT**

Pressure relief valve; vacuum function prevented by a diaphragm decoupled from the valve pallet and with Field-Test-Connection **VN-A-PCPF-ANV-FT**

Optional Equipment

Recirculation

Soft sealing EPDM*
PTFE

Sensor controlled

Vakuum pilot

Optional Accessories

Discharge blocker**

Field-Test-Kit

* For variants -NV and -ANV with set pressure >+80 mbar

** For spring pilots without recirculation

Table 1: Dimensions

Dimensions in mm / inches

To select the nominal size (DN), use the flow capacity charts on the following pages.

DN1	DN2	a	b	c	d	e	f	g
50 / 2"	50 / 2"	175 / 6.89	175 / 6.89	170 / 6.69	360 / 14.17	916 / 36.06	205 / 8.07	343 / 13.53
50 / 2"	80 / 3"	175 / 6.89	175 / 6.89	170 / 6.69	360 / 14.17	931 / 36.65	205 / 8.07	358 / 14.09
80 / 3"	80 / 3"	200 / 7.87	200 / 7.87	205 / 8.07	360 / 14.17	957 / 37.68	205 / 8.07	383 / 15.08
80 / 3"	100 / 4"	200 / 7.87	200 / 7.87	205 / 8.07	360 / 14.17	967 / 38.07	205 / 8.07	393 / 15.47
100 / 4"	100 / 4"	225 / 8.86	225 / 8.86	250 / 9.84	360 / 14.17	991 / 39.02	205 / 8.07	418 / 16.46
100 / 4"	150 / 6"	225 / 8.86	225 / 8.86	250 / 9.84	360 / 14.17	1001/39.41	205 / 8.07	428 / 16.85
150 / 6"	150 / 6"	300 / 11,81	250 / 9.84	335 / 13.19	500 / 19.69	1104 / 43.46	275 / 10.83	503 / 19.80
150 / 6"	200 / 8"	300 / 11,81	250 / 9.84	335 / 13.19	500 / 19.69	1124 / 44.25	275 / 10.83	523 / 20.59
200 / 8"	200 / 8"	375 / 14.77	300 / 11,81	410 / 16.14	630 / 24.80	1237 / 48.70	340 / 13.39	610 / 24.02
200 / 8"	250 / 10"	375 / 14.77	300 / 11,81	410 / 16.14	630 / 24.80	1267 / 49.88	340 / 13.39	640 / 25.20
250 / 10"	250 / 10"	425 / 16.73	350 / 13.78	500 / 19.69	790 / 31.10	1357 / 53.43	420 / 16.54	710 / 27.96
250 / 10"	300 / 12"	425 / 16.73	350 / 13.78	500 / 19.69	790 / 31.10	1377 / 54.41	420 / 16.54	730 / 28.74
300 / 12"	300 / 12"	500 / 19.69	400 / 15.75	570 / 22.44	920 / 36.22	1468 / 57.80	485 / 19.09	803 / 31.61
300 / 12"	350 / 14"	500 / 19.69	400 / 15.75	570 / 22.44	920 / 36.22	1488 / 58.59	485 / 19.09	823 / 32.40
300 / 12"	400 / 16"	500 / 19.69	400 / 15.75	570 / 22.44	920 / 36.22	1508 / 59.37	485 / 19.09	843 / 33.19

Table 2: Material selection for housing

Design	A	B	C
Housing	Aluminum	Stainless Steel	LTCS * (Low Temperature Carbon Steel)
Valve seat	Stainless Steel	Stainless Steel	Stainless Steel
Sealing - housing	PTFE	PTFE	PTFE
Sealing - valve disc	Metal - to - Metal	Metal - to - Metal	Metal - to - Metal
Housing diaphragm	Stainless Steel	Stainless Steel	Stainless Steel
Pilot lines	Stainless Steel	Stainless Steel	Stainless Steel
Pilot housing	Aluminum	Aluminum / Stainless Steel	Aluminum / Stainless Steel
Pilot diaphragm	FEP	FEP	FEP

* Special materials upon request.

Table 3: Flange connection type

EN 1092-1; Form B1
ASME B16.5 CL 150 R.F.

Other types upon request.

Table 4: Coefficient of Discharge

DN1	DN2	d ₀	K	DN1	DN2	d ₀	K
50 / 2"	50 / 2"	54/2.13	0,57	200 / 8"	200 / 8"	208/8.19	0.65
50 / 2"	80 / 3"	54/2.13	0,83	200 / 8"	250 / 10"	208/8.19	0.8
80 / 3"	80 / 3"	83/3.27	0,75	250 / 10"	250 / 10"	262/10.31	0.62
80 / 3"	100 / 4"	83/3.27	0,79	250 / 10"	300 / 12"	262/10.31	0.76
100 / 4"	100 / 4"	108/4.25	0.69	300 / 12"	300 / 12"	310/12.2	0.62
100 / 4"	150 / 6"	108/4.25	0.85	300 / 12"	350 / 14"	310/12.2	0.72
150 / 6"	150 / 6"	160/6.30	0.7	300 / 12"	400 / 16"	310/12.2	0.8
150 / 6"	200 / 8"	160/6.30	0.8				

DN1 = size inlet
DN2 = size outlet
d₀ = orifice diameter (mm/inches)
K = coefficient of discharge



for safety and environment

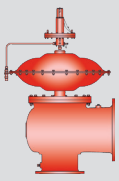

Pressure/Vacuum relief valve

Flow Capacity Charts

PROTEGO® VN-A-PCPF

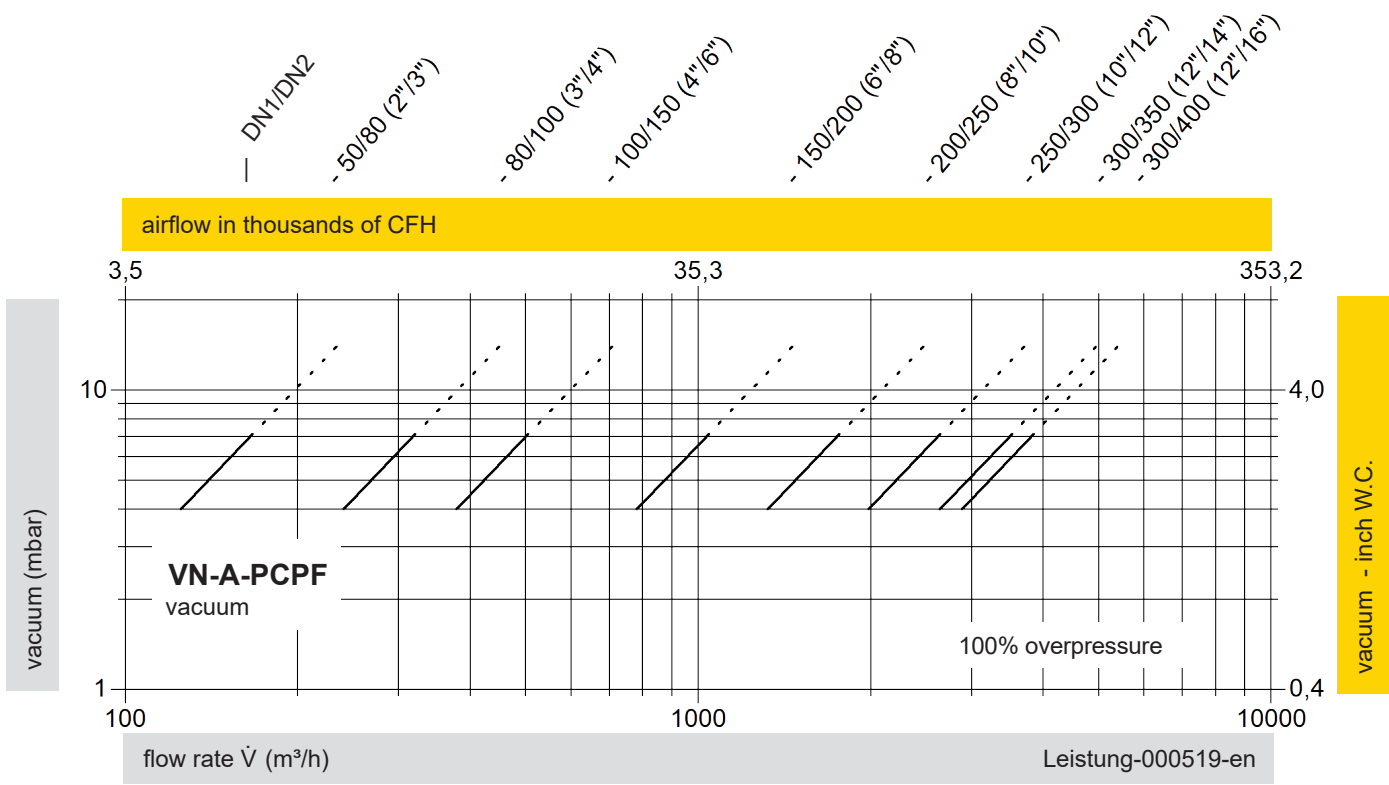
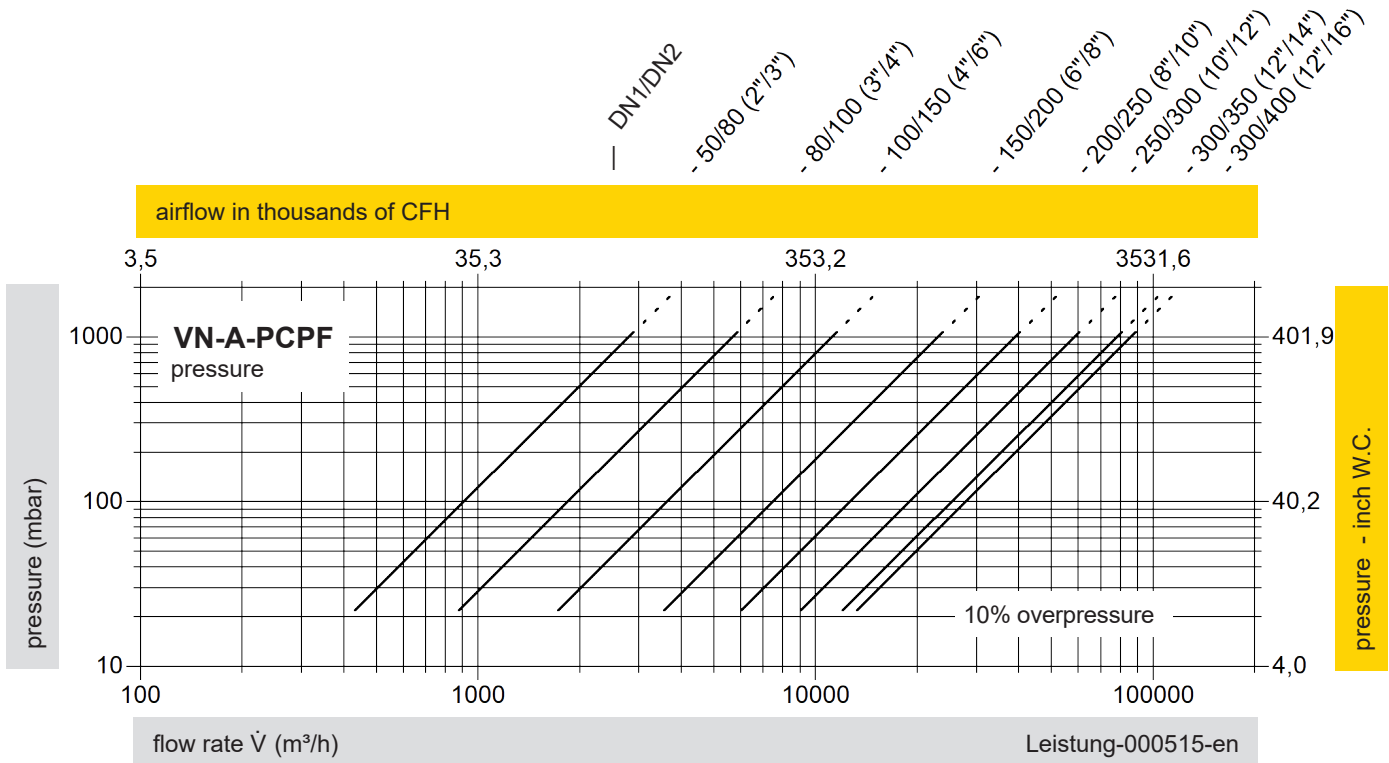

The flow capacity charts have been determined with a calibrated and TÜV certified flow capacity test rig. Volume flow \dot{V} in (m³/h) and CFH refer to the standard reference conditions of air in ISO 6358 (20°C, 1bar). For conversion to other densities and temperatures, refer to Sec. 1: "Technical Fundamentals."

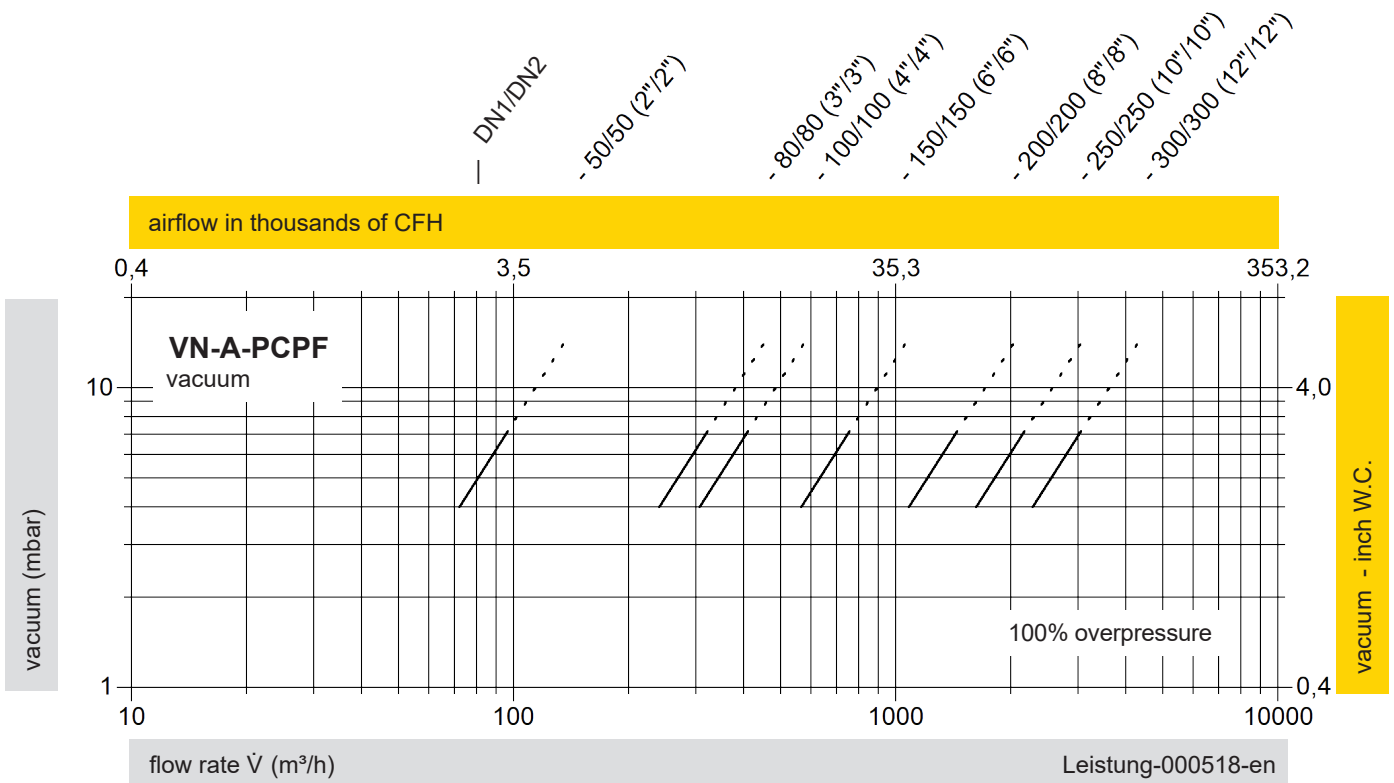
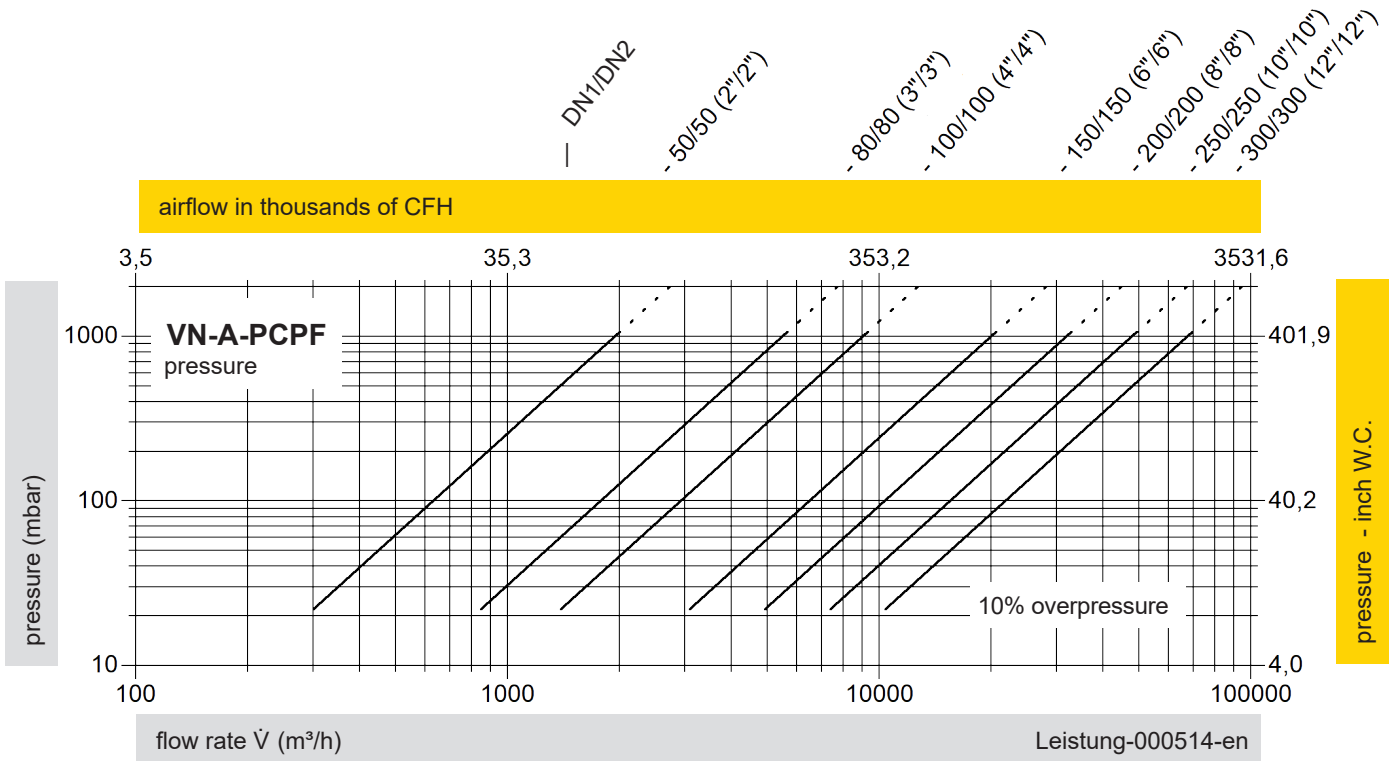

Remark: Technical Data Sheet see on page 416.



for safety and environment

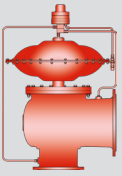

Pressure/Vacuum Relief Valve

Flow Capacity Charts

PROTEGO® VN-A-PCPF and PROTEGO® VN-A-PCPM

Project Data Sheet

Project:

Engineering:

End-user:

PROTEGO® VN-A-PCPF	<input type="checkbox"/>				
PROTEGO® VN-A-PCPM	<input type="checkbox"/>				
relief type:	pressure only	<input type="checkbox"/>			
	pressure and vacuum	<input type="checkbox"/>			
substance:					
boiling point:		°C			
molar mass:		g/mol			
total back pressure:		mbar or inch W.C.			
dynamic back pressure:		mbar or inch W.C.			
static (superimposed) back pressure:		mbar or inch W.C.			
inlet pressure drop:		mbar or inch W.C.			
set pressure:		mbar or inch W.C.			
set vacuum:		mbar or inch W.C.			
tank design code:	API 620	<input type="checkbox"/>	API 650	<input type="checkbox"/>	EN 14015 <input type="checkbox"/>
tank design pressure:		mbar			
tank design vacuum:		mbar			
material:					
required discharge per valve:		kg/h or lb/hr			
required vacuum capacity per valve at +20°C:		m³/h or SCFH			
flange connection:	ASME	<input type="checkbox"/>	EN 1092-1	<input type="checkbox"/>	JIS <input type="checkbox"/>

Fill in and check, if applicable.

signature:	date:
------------	-------