

## Pressure Relief Valve

Deflagration-proof and Endurance Burning-proof

PROTEGO® D-SVL-EB-IIA

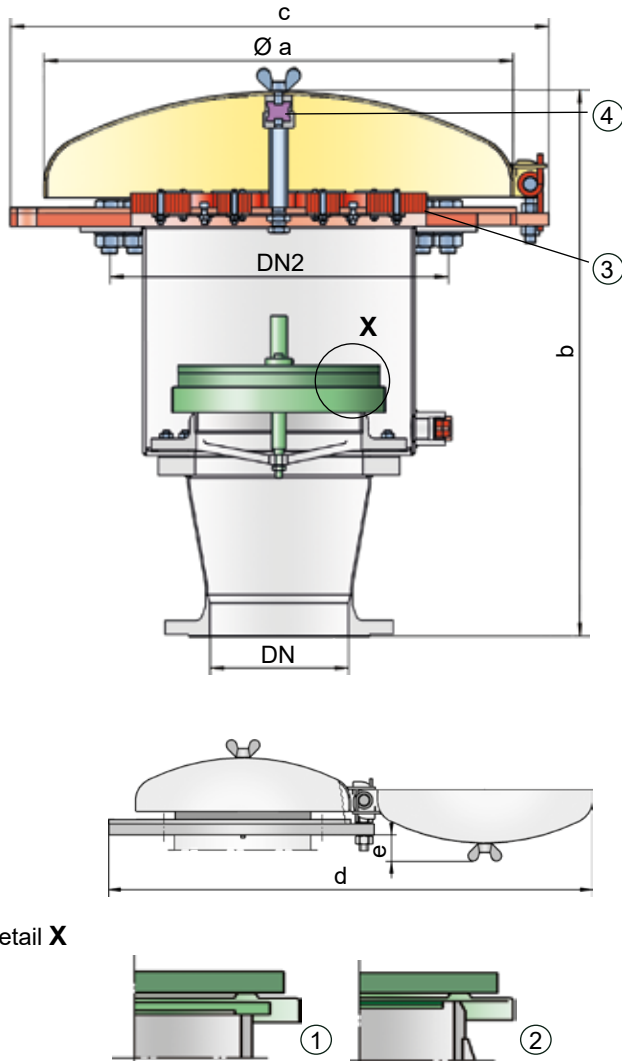

When the set pressure is reached, the valve starts to open and reaches full lift within 10% overpressure. This unique 10% technology enables a set pressure that is only 10% below the maximum allowable working pressure (MAWP) of the tank. After years of development, this typical opening characteristic of a safety relief valve is now also available for the low pressure range.

The tank pressure is maintained up to the set pressure with a tightness that is above the conventional standards due to our state-of-the-art manufacturing technology. This feature is ensured by the valve seats made of high quality stainless steel and with individually lapped valve pallets (1), or with an air cushion seal (2), in conjunction with a high quality FEP diaphragm. The valve pallets are also available with a PTFE seal to prevent the valve pallets from sticking when sticky substances are used and to enable the use in corrosive fluids. After the overpressure is released, the valve re-seats and provides a tight seal.

If the set pressure is exceeded, explosive gas/product vapor/air mixtures are released into the atmosphere. If this mixture ignites, the integrated flame arrester PROTEGO® EB (3) prevents flame transmission into the tank. If additional mixture continues to flow and stabilized burning occurs, the integrated flame arrester unit prevents flashback as a result of endurance burning. The valve is protected and also fulfils its function under these severe conditions. The spring-loaded weather hood opens as soon as the melting element (4) melts.

The valve can be used up to an operating temperature of up to +60°C / 140°F and meets the requirements of European tank design standard EN 14015 – Appendix L and ISO 28300 (API 2000).

EU conformity according to the currently valid ATEX directive. Approvals according to other national/international regulations on request.

### Special Features and Advantages

- 10% technology for minimum pressure increase up to full lift
- due to 10% technology, set pressure is close to opening pressure for optimum pressure maintenance in the system as compared to conventional 40% or 100% technology
- set pressure close to opening pressure for optimum pressure maintenance in the system
- valve opens later and closes earlier than conventional valves
- valve pallet is guided inside the housing to protect against harsh weather conditions
- can be used as a protective system in areas with potentially explosive atmospheres in accordance with ATEX
- PROTEGO® flame arrester unit provides protection against atmospheric deflagrations and endurance burning
- integrated PROTEGO® flame arrester unit saves space and weight and reduces costs
- PROTEGO® flame arrester unit is protected from clogging and sticky substances caused by product vapors
- minimum pressure loss of the PROTEGO® flame arrester unit
- flameproof condensate drain
- maintenance-friendly design
- modular design enables replacement of individual FLAMEFILTER® discs and valve pallet

### Pressure settings:

+2.0 mbar up to +60 mbar  
+0.8 inch W.C. up to +24 inch W.C.

Higher pressure settings upon request.

### Function and Description

The deflagration-proof and endurance burning-proof D-SVL-EB type PROTEGO® valve is a highly developed pressure relief valve for large flows with an integrated flame arrester PROTEGO® EB. It is primarily used as a safety device for flame transmission-proof out-breathing on tanks, containers, and process equipment. The valve offers reliable protection against excess pressure and prevents product losses almost up to the set pressure; while at the same time protecting against atmospheric deflagration and endurance burning if stabilized burning occurs. The PROTEGO® flame arrester unit is designed to achieve minimum pressure drop with maximum safety. PROTEGO® D-SVL-EB valves are available for substances for substances of explosion group IIA (NEC group D MESG > 0.9 mm).



Vents - 10% Technology  
(Flyer pdf)



Leak Rate/10% Technology  
(Flyer pdf)



Demonstration of endurance burning  
Video

## Design Types and Specifications

The valve pallet is weight-loaded.

There are two different designs:

Pressure relief valve, basic design

D-SVL-EB -

Pressure relief valve with heating jacket

D-SVL-EB -

Additional special devices available upon request.

**Table 1: Dimensions**

Dimensions in mm / inches

DN	DN2	a	b	c	d	e
150 / 6"	400 / 16"	705 / 27.76	754 / 29.68	802 / 31.57	1500 / 59.06	109 / 4.29
200 / 8"	400 / 16"	705 / 27.76	846 / 33.31	802 / 31.57	1500 / 59.06	109 / 4.29

Dimensions for pressure relief valve with heating jacket upon request.

**Table 2: Selection of explosion group**

MESG	Expl. Gr. (IEC/CEN)	Gas Group (NEC)	Special approvals upon request.
> 0,90 mm	IIA	D	

**Table 3: Material selection for housing**

Design	A	B	Special materials upon request.
Housing	Steel	Stainless Steel	
Heating jacket (D-SVL-EB-H-...)	Steel	Stainless Steel	
Valve seat	Stainless Steel	Stainless Steel	
Spacer	PTFE	PTFE	
Flange ring	Steel	Stainless Steel	
Weather hood	Steel	Stainless Steel	
Flame arrester unit	A	A, B	

**Table 4: Material combination of flame arrester unit**

Design	A	B	Special materials upon request.
FLAMEFILTER® casing	Steel	Stainless Steel	
FLAMEFILTER®	Stainless Steel	Stainless Steel	
Safety bar	Stainless Steel	Stainless Steel	

**Table 5: Material selection for valve pallet**

Design	A	B	C	D	E	F
Pressure range (mbar) (inch W.C.)	+2.0 up to +3.5 +0.8 up to +1.4	>+3.5 up to +14 >+1.4 up to +5.6	>+14 up to +35 >+5.6 up to +14	>+35 up to +60 >+14 up to +24	>+14 up to +35 >+5.6 up to +14	>+35 up to +60 >+14 up to +24
Valve pallet	Aluminum	Stainless Steel	Stainless Steel	Stainless Steel	Stainless Steel	Stainless Steel
Sealing	FEP	FEP	Metal to Metal	Metal to Metal	PTFE	PTFE

Special materials and higher pressure settings upon request.

**Table 6: Flange connection type**

EN 1092-1; Form B1	Other types upon request.
ASME B16.5 CL 150 R.F.	



for safety and environment

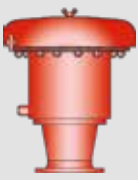

# Pressure Relief Valve

## Flow Capacity Chart

### PROTEGO® D-SVL-EB-IIA

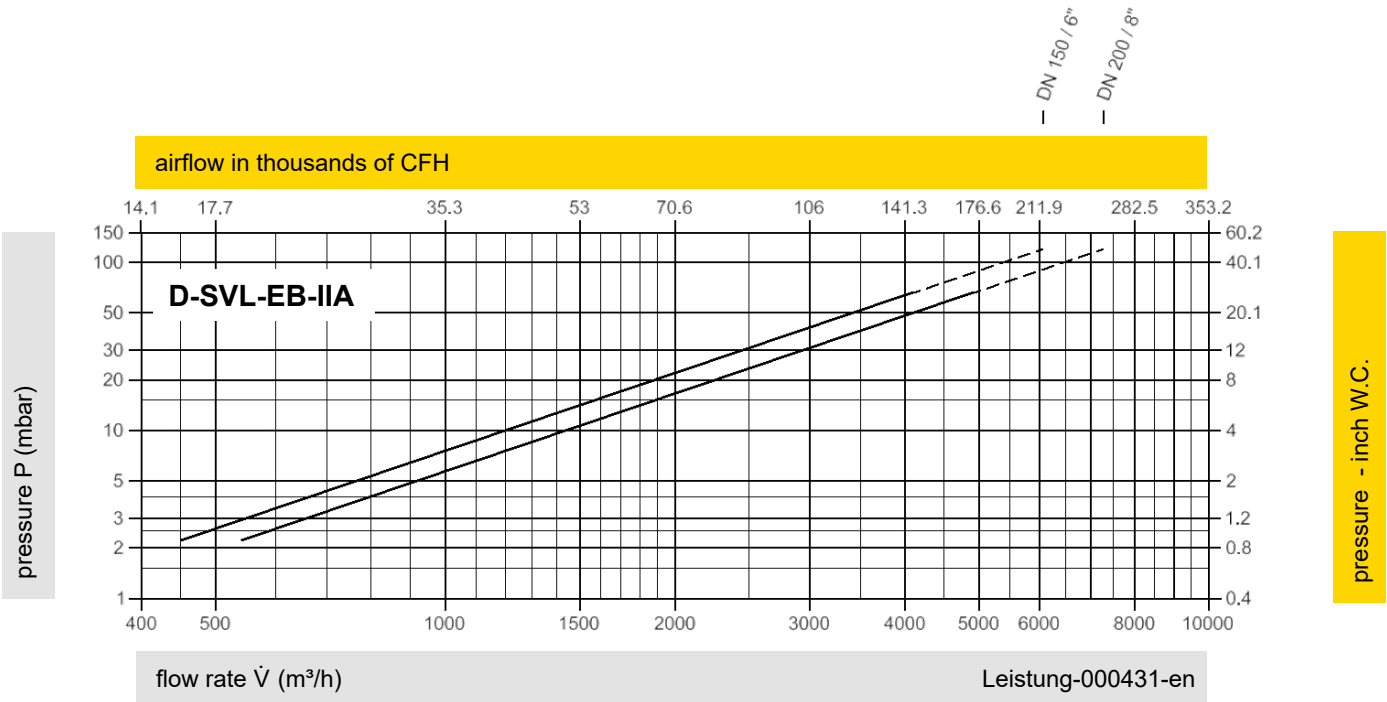

The flow capacity charts have been determined with a calibrated and TÜV certified flow capacity test rig. Volume flow  $\dot{V}$  in ( $\text{m}^3/\text{h}$ ) and CFH refer to the standard reference conditions of air in ISO 6358 (20°C, 1bar). For conversion to other densities and temperatures, refer to Sec. 1: "Technical Fundamentals."