

Deflagration Flame Arrester, endurance burning-proof, End-of-Line

PROTEGO® BE/HK-E-IIB

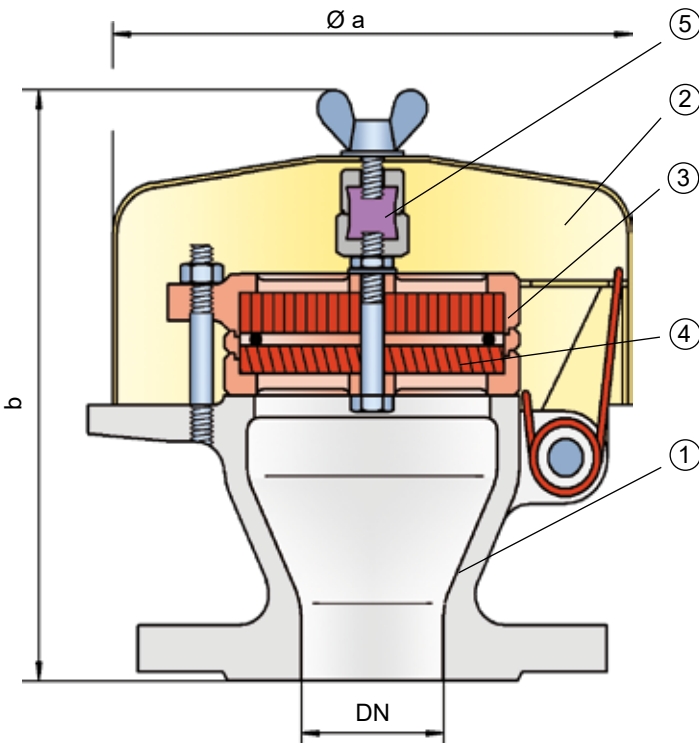

⑤ The standard design can be used for operating temperatures up to +60°C / 140°F.

② Type-approved in accordance with the current ATEX Directive and EN ISO 16852, as well as other international standards.

Special Features and Advantages

- endurance burning protection for alcohols and hydrocarbons with MESG ≥ 0,5mm
- weather hood protects the PROTEGO® flame arrester unit against environmental impact, such as nesting animals and weather conditions
- in case of fire, the weather hood opens, allowing the flame to be seen from a far distance
- centrally aligned melting element is resistant to chemicals
- modular design enables replacement of individual FLAMEFILTER® discs
- trouble-free maintenance
- provides protection against atmospheric deflagrations and endurance burning
- cost-effective spare parts

Function and Description

The PROTEGO® BE/HK-E end-of-line deflagration flame arrester was specifically developed for vessels which are not pressurized and store Ethanol or other alcohols. The combustion of alcohol requires a modified flame arrester element design to provide protection against endurance burning. In addition, the device provides protection against atmospheric deflagration. It is typically installed on in - breathing and out-breathing vent lines to prevent flame transmission into the vessel or plant caused by endurance burning or atmospheric deflagration.

The PROTEGO® BE/HK-E consists of the housing (1), a weather hood (2), and the PROTEGO® flame arrester unit (3). During normal operation, the metal weather hood is in a closed position. If a stabilized flame burns on the flame arrester element surface, the melting element (5), located in a center position, will melt, and the spring-loaded weather hood will open. The PROTEGO® flame arrester unit consists of two FLAMEFILTER® discs (4) which are installed in a FLAMEFILTER® casing. The PROTEGO® BE/HK-E end-of-line deflagration flame arrester is available for alcohols and other substances with MESG ≥ 0,5mm.

Design Types and Specifications

There are two different designs:

End-of-line deflagration flame arrester, basic design BE/HK-E -

End-of-line deflagration flame arrester with heating jacket BE/HK-E -

Special designs available upon request.

Table 1: Dimensions

Dimensions in mm / inches

To select the nominal size (DN), please use the flow capacity charts on the following pages.

DN	20 / ¾"	25 / 1"	32 / 1¼"
a	163 / 6.42	163 / 6.42	163 / 6.42
b	180 / 7.09	177 / 6.97	177 / 6.97

Dimensions for deflagration flame arrester with heating jacket upon request.

Table 2: Selection of explosion group

MESG	Expl. Gr. (IEC/CEN)	Gas Group (NEC)	Special approvals upon request.
≥ 0,5 mm	IIB	B	

Table 3: Material selection for housing

Design	B	C	Special materials upon request.
Housing	Steel	Stainless Steel	
Weather hood	Steel	Stainless Steel	
Flame arrester unit	A	A, B	

Table 4: Material combinations of flame arrester unit

Design	A	B	Special materials upon request.
FLAMEFILTER® casing	Stainless Steel	Stainless Steel	
FLAMEFILTER®	Stainless Steel	Hastelloy	
Spacer	Stainless Steel	Hastelloy	

Table 5: Flange connection type

EN 1092-1; Form B1	Other types upon request.
ASME B16.5 CL 150 R.F.	

Flow Capacity Chart

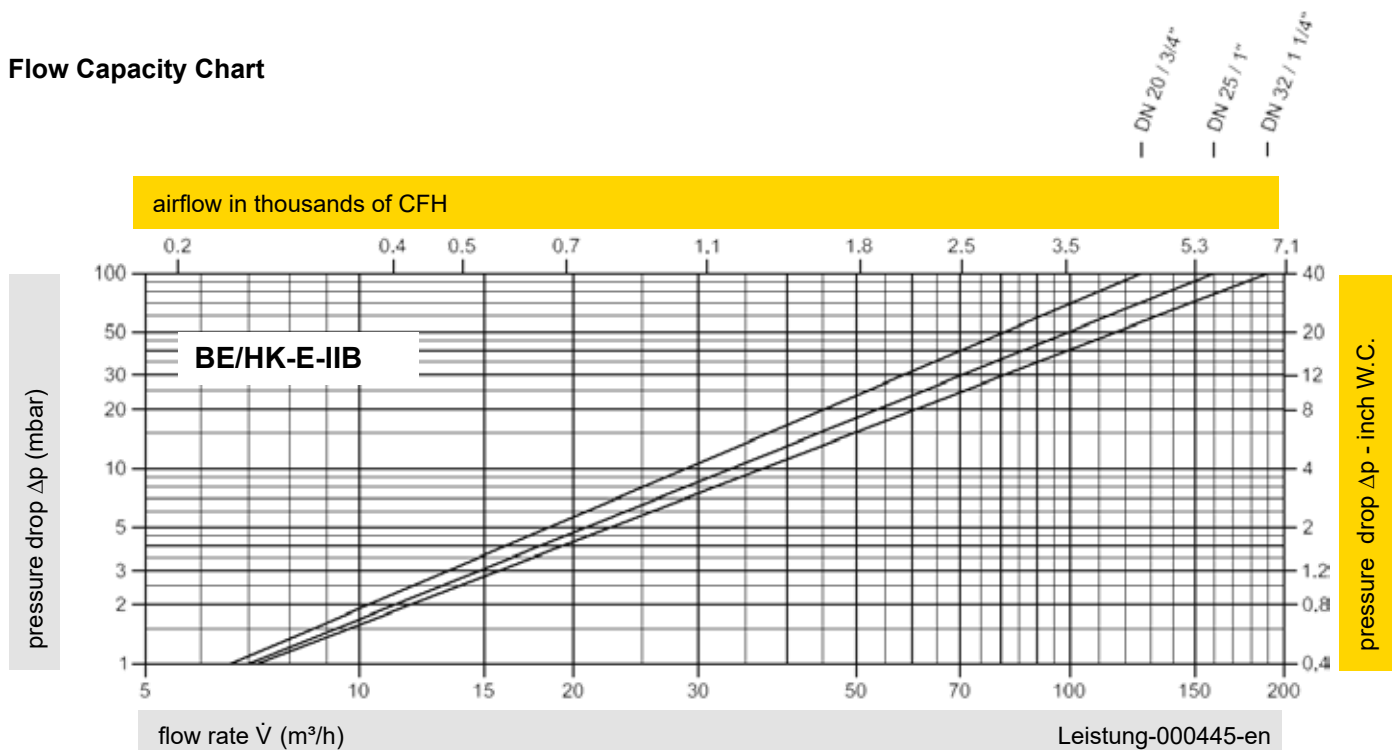

The flow capacity charts have been determined with a calibrated and TÜV certified flow capacity test rig. Volume flow \dot{V} in (m³/h) and CFH refer to the standard reference conditions of air ISO 6358 (20°C, 1bar). Conversion to other densities and temperatures refer to Vol. 1: "Technical Fundamentals".

